

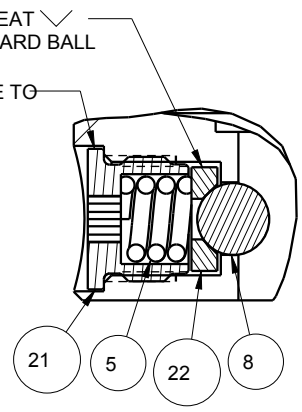

APPLY LUBRICANT TO ALL SEALS
PRIOR TO INSTALLATION.
DO NOT USE SILICONE TYPE LUBRICANTS.
FOR PROPER ARM MOUNTING SEE IS1505.



DETAIL A
SCALE 1.500

N/A	N/A	IS1505	INSTRUCTION SHEET, ARM INSTALLATION			
N/A	N/A	61704022	SPRING KIT			
N/A	N/A	6V711031	SEAL KIT, FKM			
N/A	N/A	60711031	SEAL KIT, STANDARD			
25	1	92090001	ASSY, BREATHER, SAE #4			
24	1	81591823	CAM,SC,LP,5000/22KN,LH,TC			
23	1	81591302	DISK, Ø.75 X .12			X
22	3	81532108	SEAT, BALL, SC, LP, TC			
21	3	81532107	RETAINER, SC, LP, TC			
20	1	81531811	PLUG, SC, LP, 5000&22KN, SA, TC			
19	1	81531809	CAP, END, SC, LP, 22KN/5000			
18	1	81511810	PLUNGER,SC,LP,5000&22KN,SA,TC			
17	1	39054008	BU RING,(-218)	X	X	
16	1	39054007	BU RING,(-030)	X		39054021
15	1	39053005	WIPER,SNAP-IN, (1-1/4)	X	X	
14	1	39051042	O-RING, (-030)	X		39V01021
13	2	39050042	O-RING, (-011)	X		39051025
12	1	39011060	SEAL,BEVEL W/HEEL INSERT,1-1/4 x1/8 x1-1/2	X		39052015
11	1	39011055	SEAL, BEVEL, 1-9/16 x 3/32 x 1-3/4	X		39052013
10	1	39000029	O-RING, (-115)	X	X	X
9	1	30601144	PLUG, SOCH, SAE 4			
8	3	23650004	BALL,TUNGSTEN-CARBIDE,250			
7	1	23600011	BALL, STEEL, ALLOY, .187			X
6	1	23350067	SPRING, COMPRESSION			X
5	3	23350066	SPRING, COMPRESSION			
4	2	21500200	WASHER			
3	3	21500031	SHCS, M5 x 0,8 x 14, ALY			
2	10	21500022	SHCS, M5 x .8-6G x 20, ALY			
1	2	21500019	SCREW, CAP, BTNH, M3 X 6, ALY			
No.	QTY	PART No.	DESCRIPTION	Std. Seal Kit	FKM Seal Kit	Spring Kit

PARTS LIST	 VEKTEK, INC. 1334 E. SIXTH AVE. P.O. BOX 625 EMPORIA, KS. 66801 U.S.A.	
	ASSEMBLIES AFFECTED	PARTS LIST, ASSY,SC,LP,TC,TF,5000,SA,LH
14051801		
14051801F	SIZE A	PL7184
	REV A	

A	3434	RELEASE	JDW	05/01/18
REV	IN ACCORDANCE WITH ECN	EFFECTIVE DATE	REVISED BY	DATE
DRW BY: JDW	DRAWING STATUS: Released			
DATE: 05/01/18	PRODUCTION APPROVED FOR RELEASED STATUS ONLY			

