

APPLY LUBRICANT TO ALL SEALS PRIOR TO INSTALLATION. DO NOT USE SILICONE TYPE LUBRICANTS. FOR PROPER ARM MOUNTING SEE IS1505.

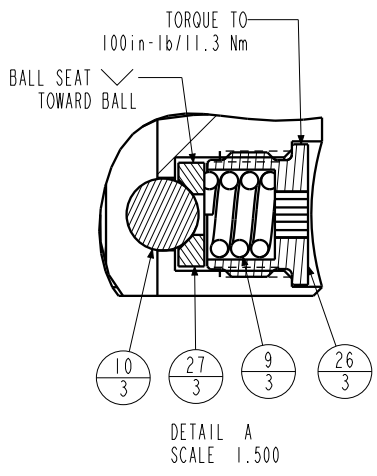

No.	QTY	PART No.	DESCRIPTION	Std. Seal Kit	FKM Seal Kit
N/A	N/A	IS1505	INSTRUCTION SHEET, ARM INSTALLATION		
N/A	N/A	6V711052	SEAL KIT, FKM		
N/A	N/A	60711052	SEAL KIT, STANDARD		
30	1	39V10029	WIPER, PRESS-IN, (1/4)	X	X
29	1	91100001	MAGNET, .130 x .312, PS		
28	1	81591837	CAM, SC, LP, 22KN, RH, LS, TC, PR		
27	3	81532108	SEAT, BALL, SC, LP, TC		
26	3	81532107	RETAINER, SC, LP, TC		
25	1	81531819	CAP, END, SC, LP, 22KN/5000, PR		
24	1	81511822	PLUNGER, SC, LP, 22KN, DA, LS, TC, PR		
23	1	81500062	HOUSING, PS, MAG, SC, LP, LS		
22	1	81500060	ADAPTOR, PS, MAG, SC, LP		
21	1	81500042	ROD, ACTUATOR, SC, LP, TF, 22KN, LS		
20	1	81500039	BUSHING, PLUNGER, PR, SC, LP		
19	1	39054008	BU RING, (-218)	X	X
18	1	39054007	BU RING, (-030)	X	39054021
17	1	39053005	WIPER, SNAP-IN, (1-1/4)	X	X
16	1	39052043	SEAL, LL, (1/4 X 1/8 X 1/8 X 1/2)	X	39V52043
15	1	39051042	O-RING, (-030)	X	39V01021
14	2	39050042	O-RING, (-011)	X	39051025
13	1	39011060	SEAL, BEVEL W/HHEEL INSERT, 1-1/4 x 1/8 x 1-1/2	X	39052015
12	1	39011056	SEAL, CROWN, 1-9/16 x 1-3/4 x 5/32	X	39V11056
11	2	30601144	PLUG, SOCH, SAE 4		
10	3	23650004	BALL, TUNGSTEN-CARBIDE, 250		
9	3	23350066	SPRING, COMPRESSION		
8	2	21500200	WASHER		
7	1	21500044	SCREW, CAP, BTNH, M3-0.5 X 6, SSTL		
6	3	21500043	SHCS, M3-0.5 X 6, ALY		
5	3	21500031	SHCS, M5 X 0.8 X 14, ALY		
4	10	21500022	SHCS, M5 X .8-6G X 20, ALY		
3	2	21500019	SCREW, CAP, BTNH, M3 X 6, ALY		
2	1	21430022	WASHER		
1	1	21410049	SCREW, CAP, SOCH, 8-32 X 3/8, ALY		

PARTS LIST

VEKTEK, INC.
1334 E. SIXTH AVE. P.O. BOX 625
EMPORIA, KS. 66801 U.S.A.

ASSEMBLIES AFFECTED	PARTS LIST, ASSY, SC, LP, TC, TF, 5000, DA, RH, LS, PS
14061803PS	
14061803FMS	
SIZE A	REV A
FORM FEG035_PL_ASIZE, REV. B	

A	3481	RELEASE	JDW	06/01/18
REV	IN ACCORDANCE WITH ECN	EFFECTIVE DATE	REVISED BY	DATE
DRW BY:	JDW	DRAWING STATUS: Released PRODUCTION APPROVED FOR RELEASED STATUS ONLY		
DATE:	06/01/18			

