

APPLY LUBRICANT TO ALL SEALS
PRIOR TO INSTALLATION.
DO NOT USE SILICONE TYPE LUBRICANTS.
FOR PROPER ARM MOUNTING SEE IS1505.

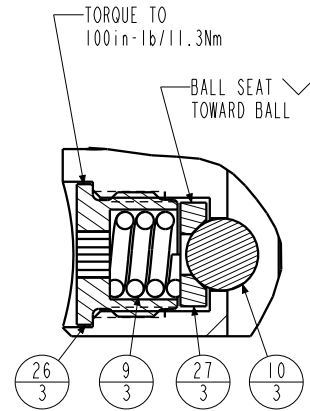

DETAIL A
SCALE 1.500

APPLY PRIMER N TO CAP SCREW,
PLUNGER AND BUSHING THREADS.
INSERT CAP SCREW THRU WASHER.
APPLY MEDIUM STRENGTH THREAD
LOCKER TO CAP SCREW THREAD
AND TORQUE TO 50 in-lb/5.6 Nm.
APPLY HIGH STRENGTH THREAD
LOCKER TO BUSHING THREAD AND
TORQUE TO 100 in-lb/11.3 Nm.

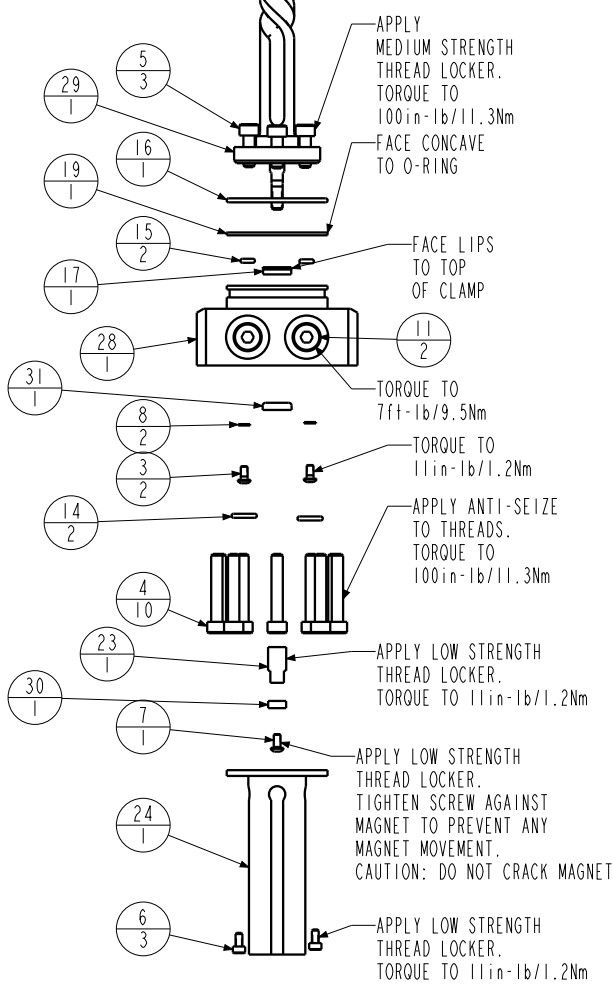

N/A	N/A	IS1505	INSTRUCTION SHEET, ARM INSTALLATION		
N/A	N/A	6V711048	SEAL KIT, FKM		
N/A	N/A	60711048	SEAL KIT, STANDARD		
31	1	39V10029	WIPER, PRESS-IN, (1/4)	X	X
30	1	91100001	MAGNET, .130 x .312, PS		
29	1	81591838	CAM, SC, LP, 22KN, LH, LS, TC, PR		
28	1	81541818	BASE, SC, BF, LP, 5000, PR		
27	3	81532108	SEAT, BALL, SC, LP, TC		
26	3	81532107	RETAINER, SC, LP, TC		
25	1	81511822	PLUNGER, SC, LP, 22KN, DA, LS, TC, PR		
24	1	81500062	HOUSING, PS, MAG, SC, LP, LS		
23	1	81500060	ADAPTOR, PS, MAG, SC, LP		
22	1	81500044	ROD, ACTUATOR, SC, LP, BF, 5000/22KN, LS		
21	1	81500039	BUSHING, PLUNGER, PR, SC, LP		
20	1	39054008	BU RING, (-218)	X	X
19	1	39054007	BU RING, (-030)	X	39054021
18	1	39053005	WIPER, SNAP-IN, (1-1/4)	X	X
17	1	39052043	SEAL, LL, (1/4 X 1/8 X 1/8 X 1/2)	X	39V52043
16	1	39051042	O-RING, (-030)	X	39V01021
15	2	39051041	O-RING, (-006)	X	39V51041
14	2	39050042	O-RING, (-011)	X	39051025
13	1	39011060	SEAL, BEVEL WHEEL INSERT, 1-1/4 x 1/8 x 1-1/2	X	39052015
12	1	39011056	SEAL, CROWN, 1-9/16 x 1-3/4 x 5/32	X	39V11056
11	2	30601144	PLUG, SOCH, SAE 4		
10	3	23650004	BALL, TUNGSTEN-CARBIDE, 250		
9	3	23350066	SPRING, COMPRESSION		
8	2	21500200	WASHER		
7	1	21500044	SCREW, CAP, BTNH, M3-0.5 X 6, SSSL		
6	3	21500043	SHCS, M3-0.5 X 6 ALY		
5	3	21500031	SHCS, M5 X 0.8 X 14, ALY		
4	10	21500023	SHCS, M5 X .8-66 X 30MM		
3	2	21500019	SCREW, CAP, BTNH, M3 X 6, ALY		
2	1	21430022	WASHER		
1	1	21410049	SCREW, CAP, SOCH, 8-32 X 3/8, ALY		
No.	QTY	PART No.	DESCRIPTION	Std. Seal Kit	FKM Seal Kit

PARTS LIST



B	4171	RELEASE	JDW	05/01/20
REV	IN ACCORDANCE WITH ECN	EFFECTIVE DATE	REVISED BY	DATE
DRW BY:	JDW	DRAWING STATUS: Released		
DATE:	03/04/19	PRODUCTION APPROVED FOR RELEASED STATUS ONLY		

ASSEMBLIES AFFECTED
14281804PS
14281804PSF

PARTS LIST, ASSY, SC, LP, TC, BF, 5000, DA, LH, LS, PS
SIZE A
PL7252
REV B

1 **2**

**READ ALL INSTRUCTIONS BEFORE INSTALLING ARMS
FAILURE TO FOLLOW INSTALLATION INSTRUCTIONS
WILL VOID PRODUCT WARRANTY !**

–Installing or Positioning of Low Profile Swing Clamp Arms–

**NOTE: If the arm is already installed on the plunger,
loosen the cap screw.**

**CAUTION: Never attempt to rotate the arm before loosening
the cap screw. This can damage the plunger rotating mechanism.**

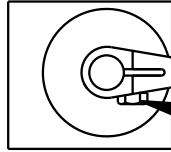

- 1. Rotate the arm to the desired radial position.**
- 2. Tighten to the torque specification listed below.**

MODEL	TORQUE ft-lb	TORQUE N-m
50001b & 22Kn	115 ft-lb	156 N-m
75001b & 33Kn	225 ft-lb	305 N-m

**IT IS RECOMMEND THE CROSS BOLT
BE REPLACED IF THE ARM NEEDS
REMOVED AFTER IT HAS BEEN IN SERVICE.**

CROSS BOLT	CROSS BOLT	CROSS BOLT	CROSS BOLT
5000 & 22KN	5000 & 22KN	7500 & 33KN	7500 & 33KN
SHORT LONG DOUBLE	UPREACH	SHORT LONG DOUBLE	UPREACH
21-5000-24	21-5000-25	21-5000-28	21-5000-25

**Instruction
Sheet**



VEKTEK, INC.
1334 E. SIXTH AVE. P.O. BOX 625
EMPORIA, KS. 66801 U.S.A.

C	2799	RELEASE	JDW	01/29/15
REV	IN ACCORDANCE WITH ECN	EFFECTIVE DATE	REVISED BY	DATE
DRW BY: MES	DRAWING STATUS: Released PRODUCTION APPROVED FOR RELEASED STATUS ONLY			
DATE: 08/01/05				

Arm Installation Instruction Sheet		
Low Profile Swing Clamps		
SIZE A	IS1505	REV C