

APPLY LUBRICANT TO ALL SEALS  
PRIOR TO INSTALLATION.  
DO NOT USE SILICONE TYPE LUBRICANTS.  
FOR PROPER ARM MOUNTING SEE IS1505.

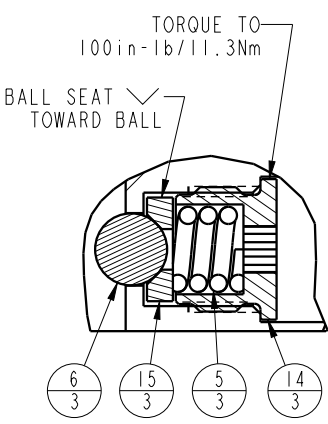

DETAIL A  
SCALE 1.500

| N/A | N/A | IS1505   | INSTRUCTION SHEET, ARM INSTALLATION    |               |              |
|-----|-----|----------|--|---------------|--------------|
| N/A | N/A | 6V711044 | SEAL KIT, FKM                          |               |              |
| N/A | N/A | 60711044 | SEAL KIT, STANDARD                     |               |              |
| 20  | 1   | 39V11051 | WIPER, PRESS-IN, (1-1/2)               | X             | X            |
| 19  | 1   | 39H52000 | SEAL, U-CUP, 1-1/2 x 1/8 x 1-3/4       | X             | 39V52000     |
| 18  | 1   | 39H51002 | O-RING, (-033)                         | X             | 39V51002     |
| 17  | 1   | 81592126 | CAM, SC, LP, 7500/33KN, RH, LS, TC     |               |              |
| 16  | 1   | 81542103 | BASE, SC, BF, LP, 7500                 |               |              |
| 15  | 3   | 81532108 | SEAT, BALL, SC, LP, TC                 |               |              |
| 14  | 3   | 81532107 | RETAINER, SC, LP, TC                   |               |              |
| 13  | 1   | 81512112 | PLUNGER, SC, LP, 7500/33KN, DA, LS, TC |               |              |
| 12  | 1   | 39054017 | BU RING, (-033)                        | X             | 39054023     |
| 11  | 1   | 39054016 | BU RING, (1.5x.125x.063)               | X             | X            |
| 10  | 1   | 39052030 | SEAL, CROWN, 1-3/4x2-1/8x1/4           | X             | 39V52030     |
| 9   | 2   | 39051041 | O-RING, (-006)                         | X             | 39V51041     |
| 8   | 2   | 39050042 | O-RING, (-011)                         | X             | 39051025     |
| 7   | 2   | 30601144 | PLUG, SOCH, SAE 4                      |               |              |
| 6   | 3   | 23650004 | BALL, TUNGSTEN-CARBIDE. 250            |               |              |
| 5   | 3   | 23350066 | SPRING, COMPRESSION                    |               |              |
| 4   | 10  | 21500305 | SHCS, M8 X 1, 25-6G X 30MM             |               |              |
| 3   | 2   | 21500200 | WASHER                                 |               |              |
| 2   | 3   | 21500031 | SHCS, M5 X 0,8 X 14, ALY               |               |              |
| 1   | 2   | 21500019 | SCREW, CAP, BTNH, M3 X 6, ALY          |               |              |
| No. | QTY | PART No. | DESCRIPTION                            | Std. Seal Kit | FKM Seal Kit |

**PARTS LIST**



VEKTEK, INC.  
1334 E. SIXTH AVE. P.O. BOX 625  
EMPORIA, KS. 66801 U.S.A.

ASSEMBLIES AFFECTED  
14222103  
14222103F

PARTS LIST, ASSY, SC, LP, TC, BF, 7500, DA, RH, LS  
SIZE A  
**PL7256**  
REV A

|         |                        |  |            |          |
|---------|------------------------|--|------------|----------|
| A       | 3677                   | RELEASE                                      | JDW        | 03/04/19 |
| REV     | IN ACCORDANCE WITH ECN | EFFECTIVE DATE                               | REVISED BY | DATE     |
| DRW BY: | JDW                    | <b>DRAWING STATUS: Released</b>              |            |          |
| DATE:   | 6-17-11                | PRODUCTION APPROVED FOR RELEASED STATUS ONLY |            |          |

**1**      **2**

# READ ALL INSTRUCTIONS BEFORE INSTALLING ARMS FAILURE TO FOLLOW INSTALLATION INSTRUCTIONS WILL VOID PRODUCT WARRANTY !

## –Installing or Positioning of Low Profile Swing Clamp Arms–

**NOTE: If the arm is already installed on the plunger,  
loosen the cap screw.**

**CAUTION: Never attempt to rotate the arm before loosening  
the cap screw. This can damage the plunger rotating mechanism.**

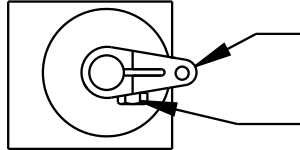

- 1. Rotate the arm to the desired radial position.**
- 2. Tighten to the torque specification listed below.**

| MODEL         | TORQUE<br>ft-lb | TORQUE<br>N-m |
|---------------|-----------------|---------------|
| 5000lb & 22Kn | 115 ft-lb       | 156 N-m       |
| 7500lb & 33Kn | 225 ft-lb       | 305 N-m       |

**IT IS RECOMMEND THE CROSS BOLT  
BE REPLACED IF THE ARM NEEDS  
REMOVED AFTER IT HAS BEEN IN SERVICE.**

| CROSS BOLT              | CROSS BOLT  | CROSS BOLT              | CROSS BOLT  |
|-------------------------|-------------|-------------------------|-------------|
| 5000 & 22KN             | 5000 & 22KN | 7500 & 33KN             | 7500 & 33KN |
| SHORT<br>LONG<br>DOUBLE | UPREACH     | SHORT<br>LONG<br>DOUBLE | UPREACH     |
| 21-5000-24              | 21-5000-25  | 21-5000-28              | 21-5000-25  |

**Instruction  
Sheet**



VEKTEK, INC.  
1334 E. SIXTH AVE. P.O. BOX 625  
EMPORIA, KS. 66801 U.S.A.

**Arm Installation Instruction Sheet**

**Low Profile Swing Clamps**

|                               |   |            |          |
|-------------------------------|---|------------|----------|
| C 2799                        | RELEASE   | JDW        | 01/29/15 |
| REV IN ACCORDANCE WITH ECN    | EFFECTIVE DATE  | REVISED BY | DATE     |
| DRW BY: MES<br>DATE: 08/01/05 | <b>DRAWING STATUS: Released</b><br>PRODUCTION APPROVED FOR RELEASED STATUS ONLY |            |          |

|           |               |          |
|-----------|---------------|----------|
| SIZE<br>A | <b>IS1505</b> | REV<br>C |
|-----------|---------------|----------|

FORM FEG041-IS-ASIZE, REV. B