



7 MPa Work Supports

Fluid Advance Bottom Flange Work Support

For Retracted Plunger Applications

B-9

- Available in four capacities from 3.0 kN to 10 kN.
- Normally retracted plungers do not interfere with part loading. Advance them with hydraulic pressure, exerting only spring force to bring plunger into contact with the part. Hydraulic pressure then automatically sequences, "freezing" the plunger properly against the part.
- Choose between a High-Tension or Low-Tension Spring to fit your application
- Plumb through BSPP ports or manifold mount. Optional flow control requires the use of manifold mount ports,
- "Floating" locator that doesn't interfere with 3-2-1 locating principles.
- Only spring force is applied to the part. Hydraulic actuation freezes the plunger without exerting any additional force on the part.
- Minimal friction wiper design keeps chips and debris out while providing smooth plunger action.
- In-port flow control valves can be used to control the plunger advance rate on support using manifold mount hydraulics.
- Optional in-port flow control is a meter-in device with reverse free flow check valve.



Shown with Optional In-Port Precision Flow Control Valve

Bearing grade stainless steel plunger and collet assembly helps guard against corrosion in most machining environments.

Specifications

Model No.	L1-0610-00-L L1-0610-00-H	L1-0612-00-L L1-0612-00-H	L1-0615-00-L L1-0615-00-H	L1-0616-00-L L1-0616-00-H
Support Capacity (kN)*	3.0	4.0	5.5	10
Support Capacity Formula (kN)**	$(P-1) \times 0.500$	$(P-1) \times 0.667$	$(P-1) \times 0.917$	$(P-1) \times 1.667$
Stroke (mm)***	6.5	8	8	10
Contact Force - L (N)	3.7 - 6.1	4.3 - 7.4	9.2 - 13.7	9.3 - 14.7
Contact Force - H (N)	6.2 - 9.0	8.8 - 14.9	12.8 - 20.7	12.7 - 22.8
Oil Capacity (cm ³)	0.55	0.80	1.02	1.49
Optional Flow Control Model No.****	L7-0203-71	L7-0203-71	L7-0203-71	L7-0203-71

Fluid Advance Work Support, hydraulic pressure pushes a spring which lifts plunger; hydraulic pressure locks in place.

WARNING: Operating above 7 MPa may damage the work support and will void warranty.

* Support capacities are listed at 7 MPa (70 bar) maximum pressure. Support capacities for other pressures are shown on the Capacity Charts on B-2. Operating work supports above maximum pressure may damage work support and void warranty.

** "P" in the formula is hydraulic pressure measured in MPa.

*** To allow for work piece height variations, it is recommended that the plunger contacts the part at Mid-Stroke.

**** Set plunger lifting time to 0.5 seconds, or longer, by adjusting the flow control valve. Use a flow control valve with cracking pressure of 0.1 MPa or less.

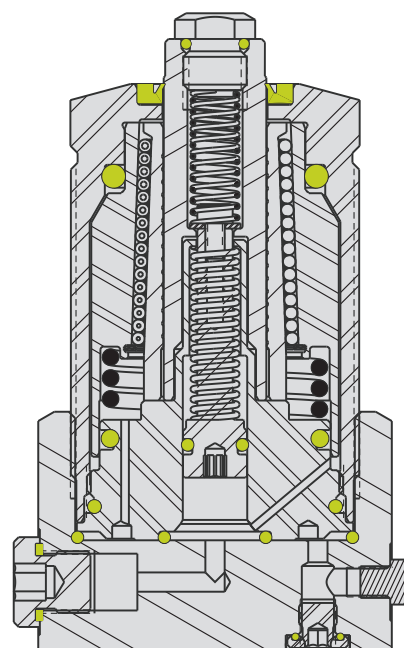

LML10600 REV D

NOTE: Work Support Capacity to be equal to or greater than 1.5 times clamping force plus machining force.

NOTE: The maximum system back-pressure a fluid advance work support can overcome is 0.07 MPa (0.7 bar). Return back-pressure greater than 0.07 MPa (0.7 bar) may cause slow or failed retraction.



7 MPa Work Supports



Fluid Advance Bottom Flange Work Support

B-10

Dimensions

Model No.	L1-0610-00-L L1-0610-00-H	L1-0612-00-L L1-0612-00-H	L1-0615-00-L L1-0615-00-H	L1-0616-00-L L1-0616-00-H
A	83	90	86	99
B	36	38	45	55
C	36	38	45	55
D	37	37	37	37
E	37	42	38	51
F	18	19	22.5	27.5
G	18	19	22.5	27.5
H	28	28	27	27
J	4.5	4.5	5.5	5.5
K	8	8	9.5	9.5
L	10.5	10.5	10.5	10.5
N	G 1/8	G 1/8	G 1/8	G 1/8
P	JIS 2401 P7	JIS 2401 P7	ID 4.0 x CS 3.0	ID 4.0 x CS 3.0
Q	10	12	15	16
R	6.5	8	8	10
S	9	11.5	12.5	12.5
T	3	4	4	4
V	8	10	11	11
W	8	10	13	13
X	8.75	8.75	8.75	12.25
Y	M5 x 0.8	M5 x 0.8	M5 x 0.8	M5 x 0.8
MA	M26 X 1.5	M30 X 1.5	M36 x 1.5	M45 x 1.5
MB	13.5	14.5	17	22
MC	13.5	14.5	17	22
MD	M4	M4	M5	M5
ME	7	7	9	10
MF	7	7	9	10
MG	3	3	3	3
MH	9	11	13	16

Fluid Advance Work Supports; hydraulic pressure pushes a spring which lifts plunger, hydraulic pressure locks in place.

Refer to contact bolt dimensions on page B-2

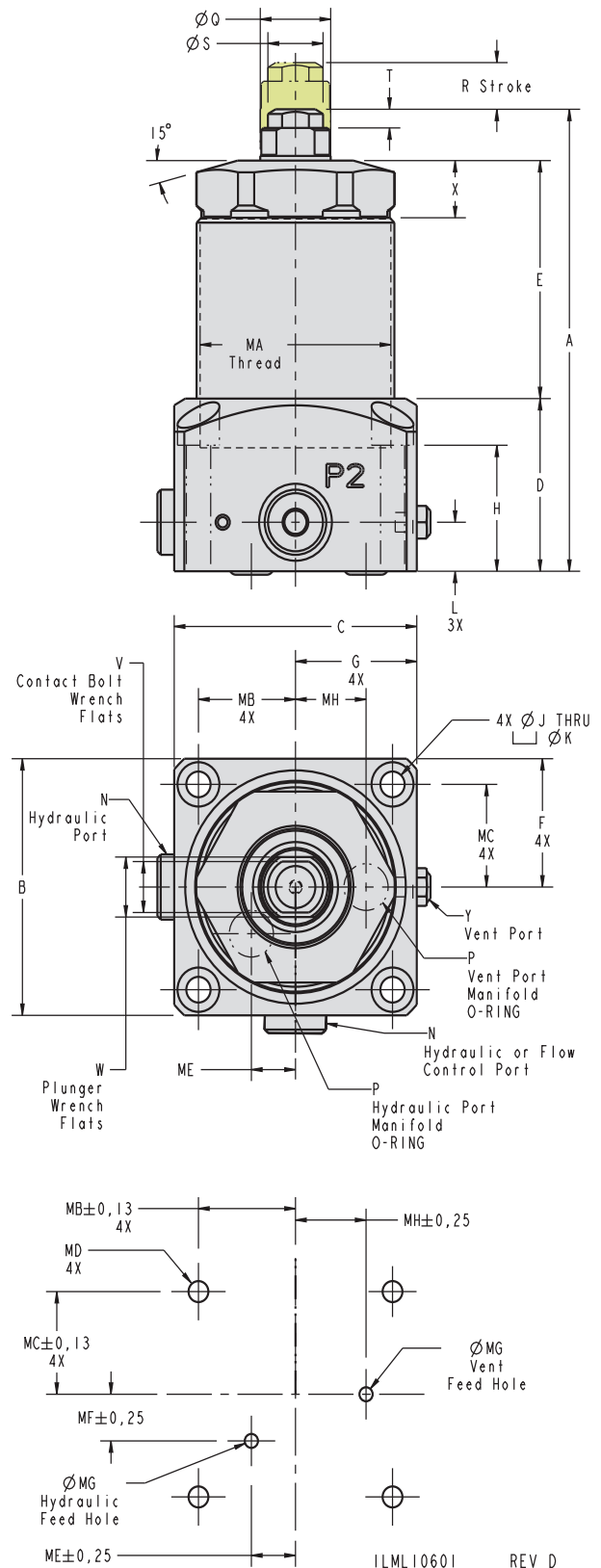

For proper sealing, the mating surface must be flat within 0.08 mm with a maximum surface roughness of 1.6 μm R_a



7 MPa Work Supports

Features, Capacity, Flow Rates

Standard Features

- Highly repeatable work supports, repeat position ± 0.005 mm.
- Designed for maximum capacity in a minimal envelope.
- Collet Locking provides a tremendous mechanical advantage for use in 7 MPa applications.
- Piston areas have been optimized for increased holding force and safety.
- Available with a high or low contact spring force.
- Proprietary wiper and seal designs reduce contamination and drag for longer lasting, better performing work supports.
- Supports can be manifold mounted or plumbed.
- Install cartridge mount work supports into customer machined cavities.

Easy-access standard G 1/4 and G 1/8 porting to both the clamp and vent ports for remote venting or air purge. (Bronze filter installed before shipping).

Special corrosion resistant high quality bearing grade stainless steel plunger and collet assembly reduces the tendency to stick.



Spring Advance

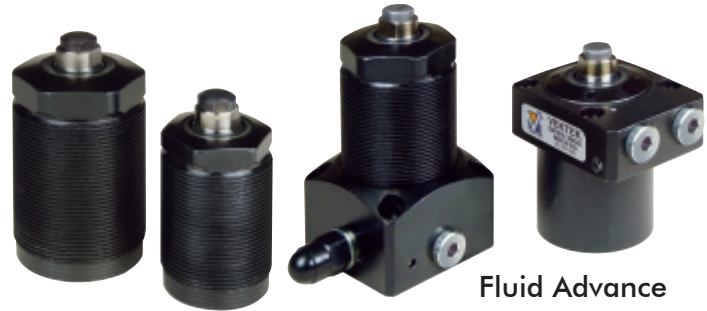

Fluid Advance

B-2

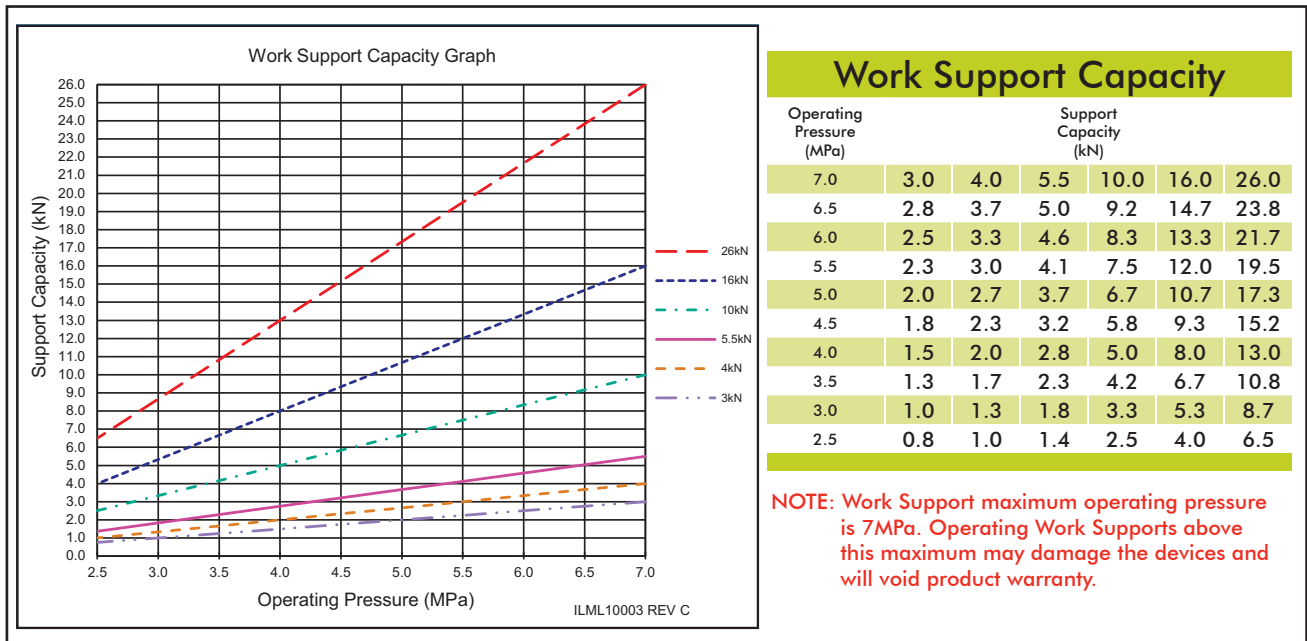

Work Support Capacity

Operating Pressure (MPa)	3.0	4.0	5.5	10.0	16.0	26.0
7.0	3.0	4.0	5.5	10.0	16.0	26.0
6.5	2.8	3.7	5.0	9.2	14.7	23.8
6.0	2.5	3.3	4.6	8.3	13.3	21.7
5.5	2.3	3.0	4.1	7.5	12.0	19.5
5.0	2.0	2.7	3.7	6.7	10.7	17.3
4.5	1.8	2.3	3.2	5.8	9.3	15.2
4.0	1.5	2.0	2.8	5.0	8.0	13.0
3.5	1.3	1.7	2.3	4.2	6.7	10.8
3.0	1.0	1.3	1.8	3.3	5.3	8.7
2.5	0.8	1.0	1.4	2.5	4.0	6.5

NOTE: Work Support maximum operating pressure is 7MPa. Operating Work Supports above this maximum may damage the devices and will void product warranty.

Self-Produced Contact Bolts S/A Work Supports

Model No.	L1-0X10-XX-X	L1-0X12-XX-X	L1-0X15-XX-X	L1-0X16-XX-X	L1-0X20-XX-X	L1-0X22-XX-X
Capacity	3 kN	4 kN	5.5 kN	10 kN	16 kN	26 kN
O-ring Part No.	39-0511-18	39-0511-08	39-0510-91		39-0511-32	
A	4.55	5.75	7.80		9.35	
B	9.0	11.5	12.5		16.5	
C	3.35	4.35	5.75		6.88	
D	9.0	9.0	9.0		9.0	
E	6.25	6.25	6.25		6.0	
F	1.75	1.75	1.75		2.0	
G	M6 x 1.0	M8 x 1.25	M10 x 1.5		M12 x 1.75	

For All 7 MPa Work Supports

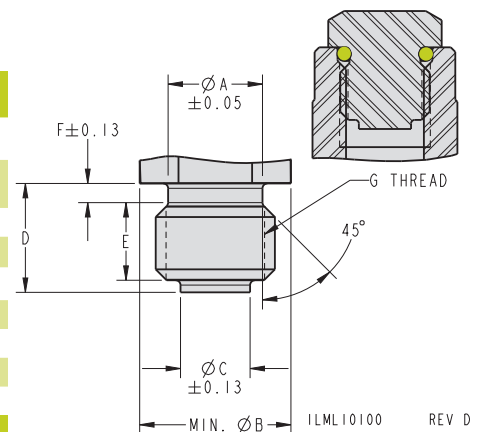

7 MPa Work Support and Clamp Systems

Clamps and Work Supports as a System

- Link Clamps, Swing Clamps, and Work Supports are designed to work as a system.
- Clamps and Work Supports work together at the same pressure.
- Sequencing is required and must occur above 2.5 MPa.
- Clamps do not need pressure reduction when clamping over a work support and operating in the range of 4 to 7 MPa. This applies even when Vektek extended arms are used.

Off the shelf Swing Clamp arms and Link Clamp levers designed to the correct length for clamping over work support centerline.

Swing Clamp arms can be found on page D-2 and Link Clamp Levers on page F-1.



**Clamping Over Work Supports,
Paired for your Convenience**

Swing or Link Clamps Paired with the Right Work Support

Clamping Force (kN)	Swing Clamp Models	Bore Size	Link Clamp Models	Work Support Models	Work Support Capacity (kN)
0.9 - 1.7	L1-4X25-00	25	L1-6025-00	L1-0X12-00	4.0
1.6 - 3.2	L1-4X32-00	32	L1-6032-00	L1-0X15-00	5.5
2.6 - 5.1	L1-4X40-00	40	L1-6040-00	L1-0X16-00	10.0
4.3 - 7.6	L1-4X50-00	50	L1-6050-00	L1-0X20-00	16.0
6.9 - 12.6	L1-4X63-00	63	L1-6063-00	L1-0X22-00	26.0

Pairs deliver at least 1.5 to 1 Work Support to Clamp Capacity Ratio

WARNING: Operating Work Supports above 7 MPa may damage the work support and will void warranty.

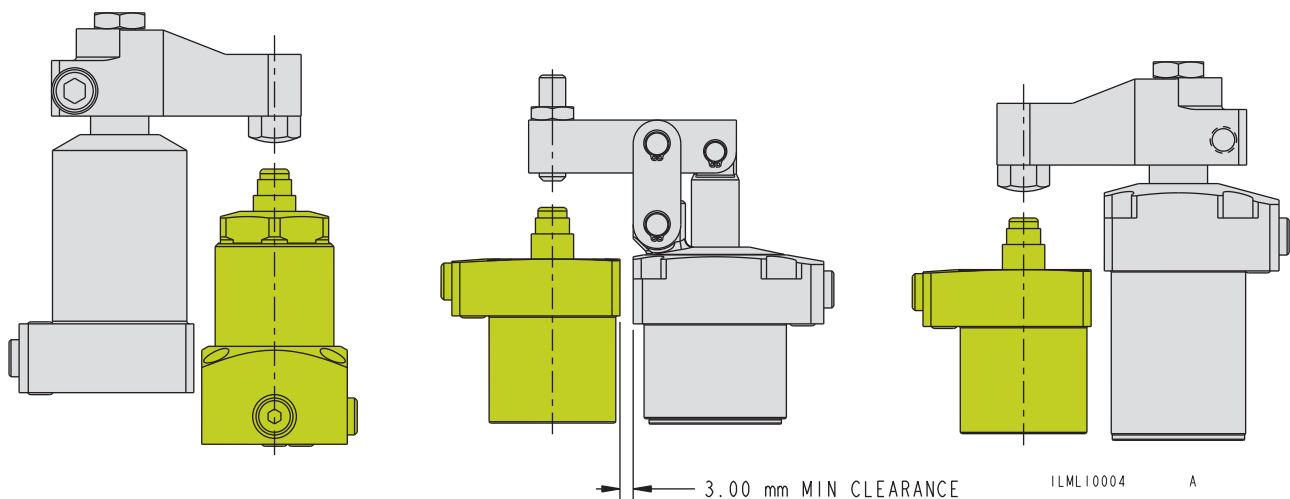

7 MPa Work Support and Clamp Systems

Clamp sequencing must always occur above 2.5 MPa.

Operating Pressure (MPa)	4.0 kN Work Support Work Support Capacity (kN)	25 Bore Swing Clamp Swing Clamp Force (kN)*	Swing Clamp to Work Support Support Capacity Ratio	25 Bore Link Clamp Link Clamp Force (kN)**	Link Clamp to Work Support Support Capacity Ratio
7.0	4.0	1.7	2.4	1.5	2.7
6.0	3.3	1.4	2.4	1.3	2.6
5.0	2.7	1.2	2.3	1.1	2.5
4.0	2.0	0.9	2.1	0.9	2.2

ILML10005-4.0 REV A *Using L9-1425-01 Arm **Using L9-1625-03 Lever

Operating Pressure (MPa)	5.5 kN Work Support Work Support Capacity (kN)	32 Bore Swing Clamp Swing Clamp Force (kN)*	Swing Clamp to Work Support Support Capacity Ratio	32 Bore Link Clamp Link Clamp Force (kN)**	Link Clamp to Work Support Support Capacity Ratio
7.0	5.5	3.2	1.7	2.9	1.9
6.0	4.6	2.7	1.7	2.5	1.8
5.0	3.7	2.3	1.6	2.0	1.9
4.0	2.8	1.8	1.6	1.6	1.8

ILML10005-5.5 REV A *Using L9-1432-01 Arm **Using L9-1632-03 Lever

Operating Pressure (MPa)	10 kN Work Support Work Support Capacity (kN)	40 Bore Swing Clamp Swing Clamp Force (kN)*	Swing Clamp to Work Support Support Capacity Ratio	40 Bore Link Clamp Link Clamp Force (kN)**	Link Clamp to Work Support Support Capacity Ratio
7.0	10.0	5.1	2.0	4.5	2.2
6.0	8.3	4.4	1.9	3.9	2.1
5.0	6.7	3.7	1.8	3.2	2.1
4.0	5.0	2.9	1.7	2.6	1.9

ILML10005-10 REV A *Using L9-1440-01 Arm **Using L9-1640-03 Lever

Operating Pressure (MPa)	16 kN Work Support Work Support Capacity (kN)	50 Bore Swing Clamp Swing Clamp Force (kN)*	Swing Clamp to Work Support Support Capacity Ratio	50 Bore Link Clamp Link Clamp Force (kN)**	Link Clamp to Work Support Support Capacity Ratio
7.0	16.0	7.6	2.1	7.6	2.1
6.0	13.3	6.5	2.0	6.5	2.0
5.0	10.7	5.4	2.0	5.4	2.0
4.0	8.0	4.3	1.9	4.4	1.8

ILML10005-16 REV A *Using L9-1450-01 Arm **Using L9-1650-03 Lever

Operating Pressure (MPa)	26 kN Work Support Work Support Capacity (kN)	63 Bore Swing Clamp Swing Clamp Force (kN)*	Swing Clamp to Work Support Support Capacity Ratio	63 Bore Link Clamp Link Clamp Force (kN)**	Link Clamp to Work Support Support Capacity Ratio
7.0	26.0	12.0	2.2	12.6	2.1
6.0	21.7	10.3	2.1	10.8	2.0
5.0	17.3	8.6	2.0	9.0	1.9
4.0	13.0	6.9	1.9	7.2	1.8

ILML10005-26 REV A *Using L9-1463-01 Arm **Using L9-1663-03 Lever

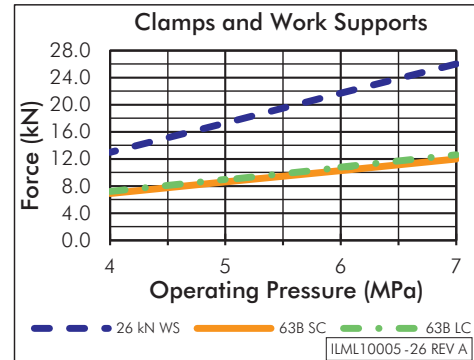
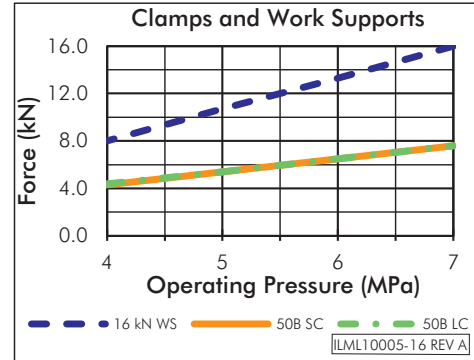
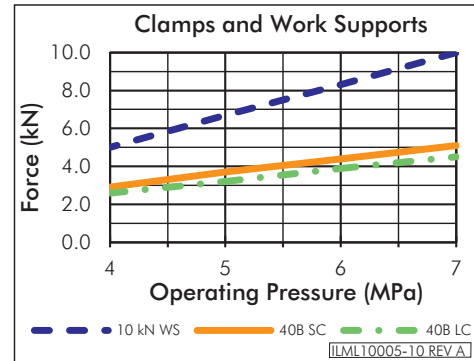
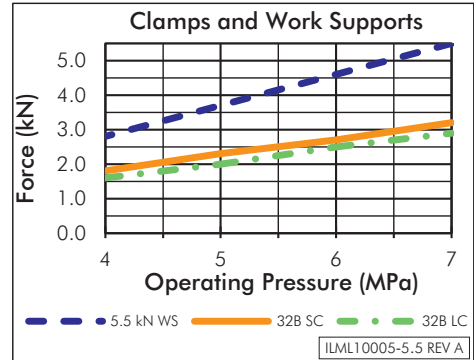
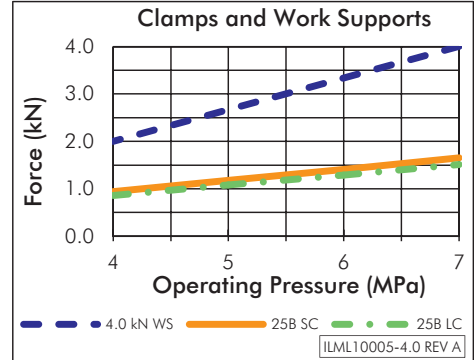

B-16