



7 MPa Work Supports

Spring Advance Cartridge Work Support

For Supporting Most Parts

- Available in four capacities from 3.0 kN, 4.0 kN, 5.5 kN and 10 kN.
- When using the 3-2-1 locating principles, you often need additional support for a 4th, 5th or even more areas on your part. A work support will give you "floating" locators that won't interfere with your 3, 2 or 1 location. Clamp over your locators then lock the supports.
- Spring extended plungers maintain contact with the part during loading, exerting only spring force against the part. When hydraulic pressure is applied the plunger freezes without exerting any additional force on the part.
- If spring advance supports are used in flood coolant environments, vent to clean dry air.
- Choose between a High-Tension or Low-Tension spring to fit your application.
- Cartridge style work supports provide designers with additional mounting options. These supports can be thread mounted into a fixture or custom cavity mounted.



Bearing grade stainless steel plunger and collet assembly helps guard against corrosion in most machining environments.

Vent Spring Advance Work Supports to dry air when used in flood coolant environments.

Specifications

Model No.	L1-0310-00-L L1-0310-00-H	L1-0312-00-L L1-0312-00-H	L1-0315-00-L L1-0315-00-H	L1-0316-00-L L1-0316-00-H
Support Capacity (kN)*	3.0	4.0	5.5	10
Support Capacity Formula (kN)**	(P-1) x 0.500	(P-1) x 0.667	(P-1) x 0.917	(P-1) x 1.667
Stroke (mm)***	6.5	8	8	10
Contact Force - L (N)	3.7 - 6.1	4.3 - 7.4	9.2 - 13.7	9.3 - 14.7
Contact Force - H (N)	6.2 - 9.0	8.8 - 14.9	12.8 - 20.7	12.7 - 22.8
Oil Capacity (cm ³)	0.30	0.40	0.39	0.70

Spring Advance Work Supports; spring lifts plunger, part weight depresses plunger, hydraulic pressure locks in place.

WARNING: Operating above 7 MPa may damage the work support and will void warranty.

* Support capacities are listed at 7 MPa (70 bar) maximum pressure. Support capacities for other pressures are shown on the Capacity Charts on B-2. Operating work supports above maximum pressure may damage work support and void warranty.

** "P" in the formula is hydraulic pressure measured in MPa.

*** To allow for work piece height variations, it is recommended that the plunger contacts the part at Mid-Stroke.

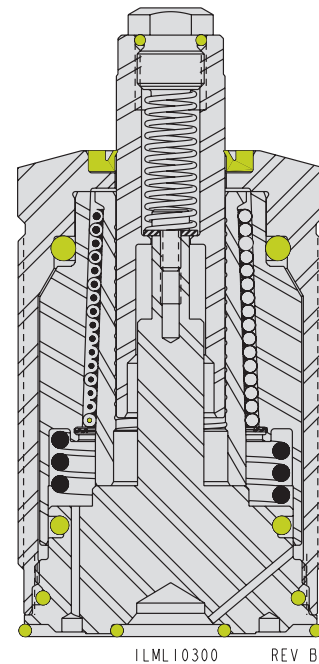

NOTE: Work Support Capacity to be equal to or greater than 1.5 times clamping force plus machining force.



7 MPa Work Supports



Spring Advance Cartridge Work Support

B-12

Dimensions

Model No.	L1-0310-00-L L1-0310-00-H	L1-0312-00-L L1-0312-00-H	L1-0315-00-L L1-0315-00-H	L1-0316-00-L L1-0316-00-H
A	72.5	81	77	92
B	24	27	32	41
C	26	30	36	45
D	8.4	9.4	9.4	9.4
E	57	62	58	71
Q	AS568 2-013	AS568 2-014	AS568 2-015	AS568 2-015
P	10	12	15	16
R	6.5	8	8	10
S	9	11.5	12.5	12.5
T	3	4	4	4
V	8	10	11	11
W	8	10	13	13
X	8.75	8.75	8.75	12.25
Y	AS568 2-020	AS568 2-022	AS568 2-026	AS568 2-030
Z	24.25	28.25	34.25	43.15
MA	M26 X 1.5	M30 X 1.5	M36 x 1.5	M45 x 1.5
MG	Max. 7	Max. 8	Max. 10	Max. 10
MH	18.5	20	24.5	30
MK	Max. 3	Max. 4	Max. 4	Max. 6
ML	24.5	28.5	34.5	43.5
MM	Min. 20	Min. 20	Min. 18	Min. 20
MN	Max. 8	Max. 9	Max. 9	Max. 9
Install Torque	35 Nm	40 Nm	40 Nm	55 Nm

Spring Advance Work Supports; spring lifts plunger, part weight depresses plunger, hydraulic pressure locks in place.

Refer to contact bolt dimensions on page B-2

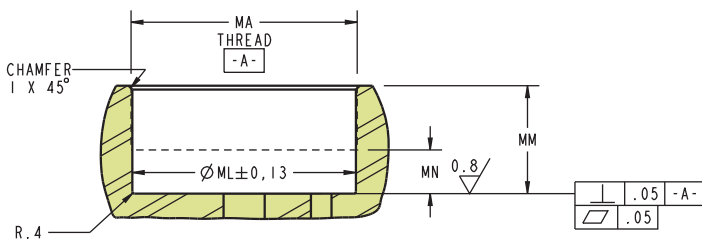
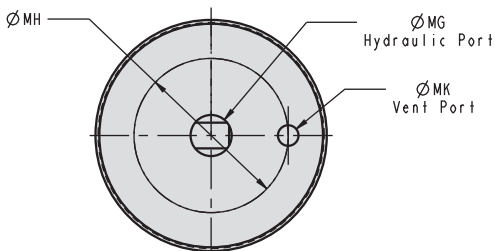
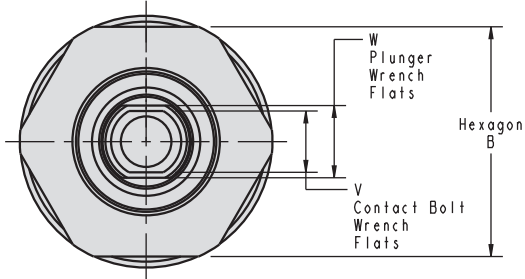
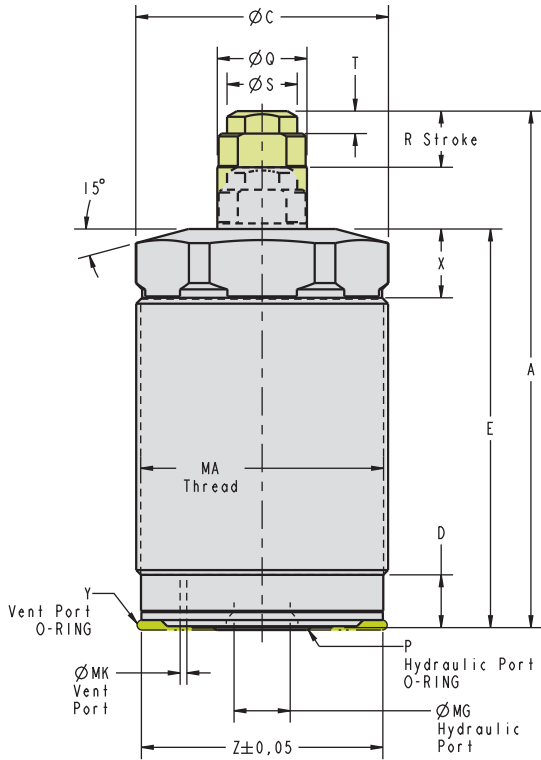

1LML10301 REV C

7 MPa Work Supports

Features, Capacity, Flow Rates

Standard Features

- Highly repeatable work supports, repeat position ± 0.005 mm.
- Designed for maximum capacity in a minimal envelope.
- Collet Locking provides a tremendous mechanical advantage for use in 7 MPa applications.
- Piston areas have been optimized for increased holding force and safety.
- Available with a high or low contact spring force.
- Proprietary wiper and seal designs reduce contamination and drag for longer lasting, better performing work supports.
- Supports can be manifold mounted or plumbed.
- Install cartridge mount work supports into customer machined cavities.

Easy-access standard G 1/4 and G 1/8 porting to both the clamp and vent ports for remote venting or air purge. (Bronze filter installed before shipping).

Special corrosion resistant high quality bearing grade stainless steel plunger and collet assembly reduces the tendency to stick.



Spring Advance

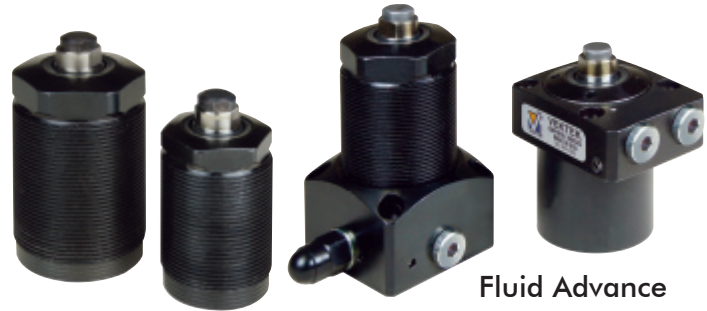

Fluid Advance

B-2

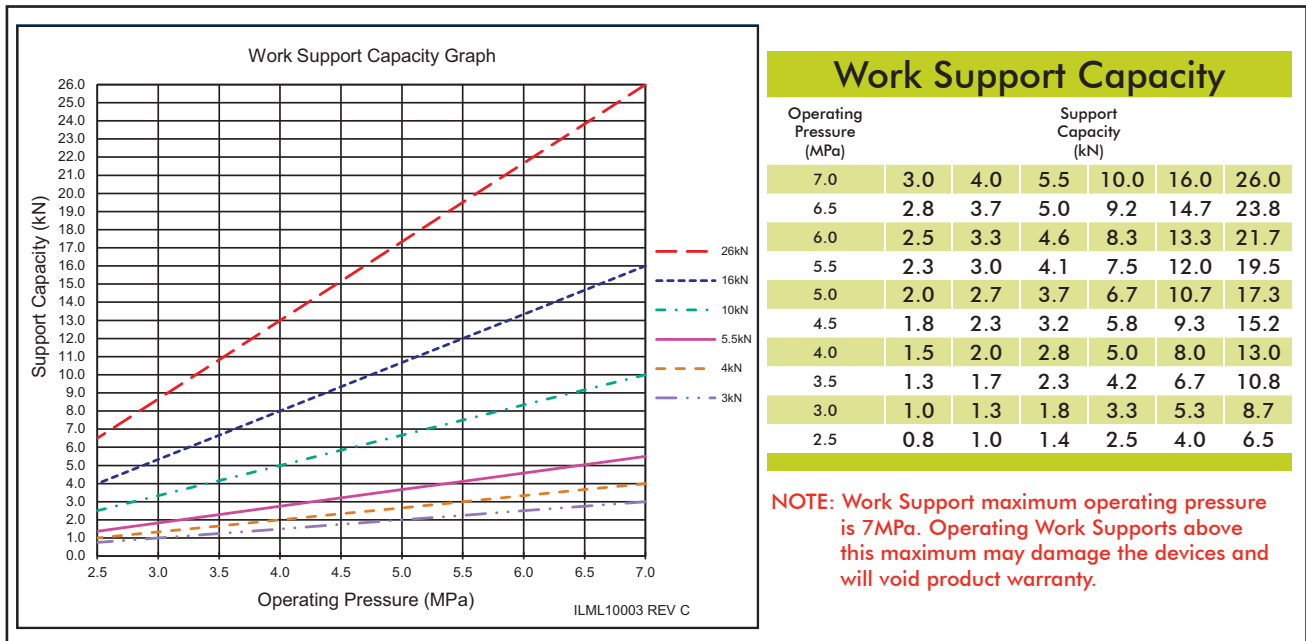

Self-Produced Contact Bolts S/A Work Supports

Model No.	L1-0X10-XX-X	L1-0X12-XX-X	L1-0X15-XX-X	L1-0X16-XX-X	L1-0X20-XX-X	L1-0X22-XX-X
Capacity	3 kN	4 kN	5.5 kN	10 kN	16 kN	26 kN
O-ring Part No.	39-0511-18	39-0511-08	39-0510-91		39-0511-32	
A	4.55	5.75	7.80		9.35	
B	9.0	11.5	12.5		16.5	
C	3.35	4.35	5.75		6.88	
D	9.0	9.0	9.0		9.0	
E	6.25	6.25	6.25		6.0	
F	1.75	1.75	1.75		2.0	
G	M6 x 1.0	M8 x 1.25	M10 x 1.5		M12 x 1.75	

For All 7 MPa Work Supports

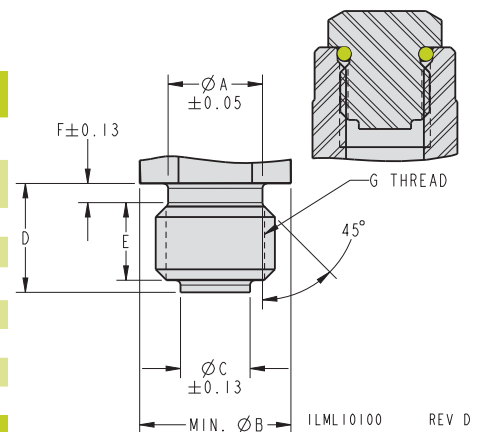

7 MPa Work Support and Clamp Systems

Clamps and Work Supports as a System

- Link Clamps, Swing Clamps, and Work Supports are designed to work as a system.
- Clamps and Work Supports work together at the same pressure.
- Sequencing is required and must occur above 2.5 MPa.
- Clamps do not need pressure reduction when clamping over a work support and operating in the range of 4 to 7 MPa. This applies even when Vektek extended arms are used.

Off the shelf Swing Clamp arms and Link Clamp levers designed to the correct length for clamping over work support centerline.

Swing Clamp arms can be found on page D-2 and Link Clamp Levers on page F-1.



**Clamping Over Work Supports,
Paired for your Convenience**

Swing or Link Clamps Paired with the Right Work Support

Clamping Force (kN)	Swing Clamp Models	Bore Size	Link Clamp Models	Work Support Models	Work Support Capacity (kN)
0.9 - 1.7	L1-4X25-00	25	L1-6025-00	L1-0X12-00	4.0
1.6 - 3.2	L1-4X32-00	32	L1-6032-00	L1-0X15-00	5.5
2.6 - 5.1	L1-4X40-00	40	L1-6040-00	L1-0X16-00	10.0
4.3 - 7.6	L1-4X50-00	50	L1-6050-00	L1-0X20-00	16.0
6.9 - 12.6	L1-4X63-00	63	L1-6063-00	L1-0X22-00	26.0

Pairs deliver at least 1.5 to 1 Work Support to Clamp Capacity Ratio

WARNING: Operating Work Supports above 7 MPa may damage the work support and will void warranty.

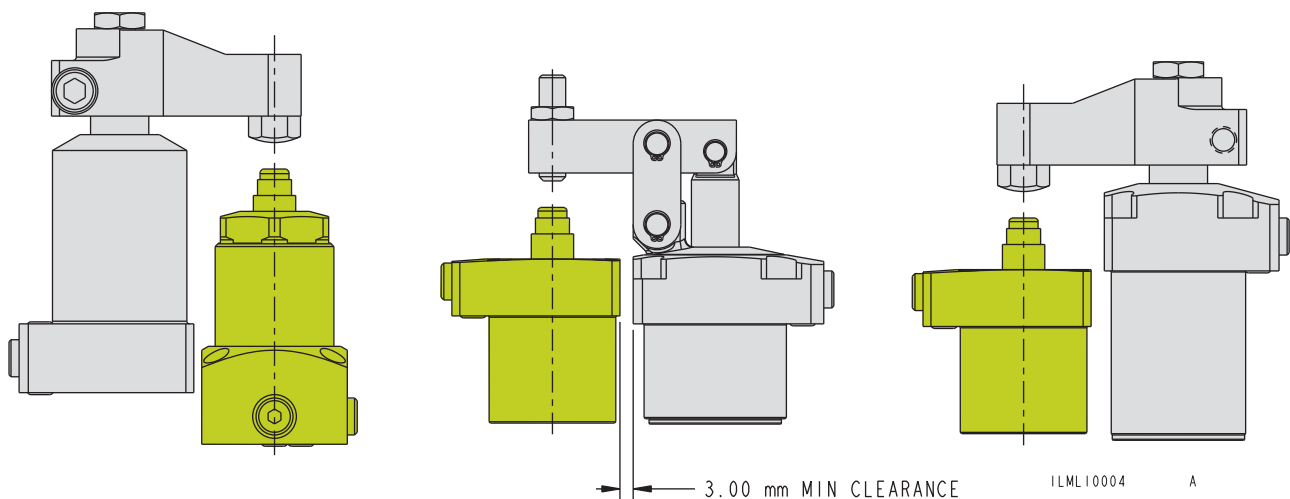

7 MPa Work Support and Clamp Systems

Clamp sequencing must always occur above 2.5 MPa.

B-16

Operating Pressure (MPa)	4.0 kN Work Support Work Support Capacity (kN)	25 Bore Swing Clamp Swing Clamp Force (kN)*	Swing Clamp to Work Support Support Capacity Ratio	25 Bore Link Clamp Link Clamp Force (kN)**	Link Clamp to Work Support Support Capacity Ratio
7.0	4.0	1.7	2.4	1.5	2.7
6.0	3.3	1.4	2.4	1.3	2.6
5.0	2.7	1.2	2.3	1.1	2.5
4.0	2.0	0.9	2.1	0.9	2.2

ILML10005-4.0 REV A *Using L9-1425-01 Arm **Using L9-1625-03 Lever

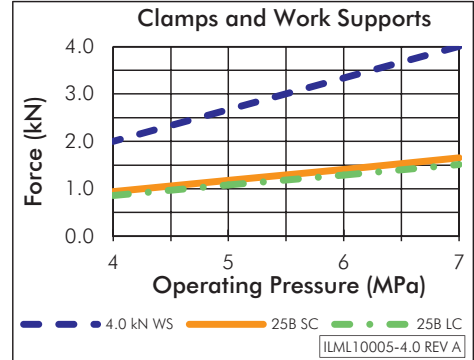

Operating Pressure (MPa)	5.5 kN Work Support Work Support Capacity (kN)	32 Bore Swing Clamp Swing Clamp Force (kN)*	Swing Clamp to Work Support Support Capacity Ratio	32 Bore Link Clamp Link Clamp Force (kN)**	Link Clamp to Work Support Support Capacity Ratio
7.0	5.5	3.2	1.7	2.9	1.9
6.0	4.6	2.7	1.7	2.5	1.8
5.0	3.7	2.3	1.6	2.0	1.9
4.0	2.8	1.8	1.6	1.6	1.8

ILML10005-5.5 REV A *Using L9-1432-01 Arm **Using L9-1632-03 Lever

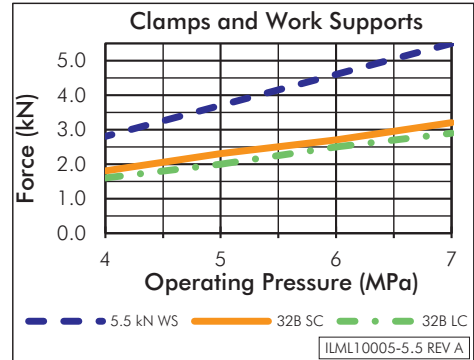

Operating Pressure (MPa)	10 kN Work Support Work Support Capacity (kN)	40 Bore Swing Clamp Swing Clamp Force (kN)*	Swing Clamp to Work Support Support Capacity Ratio	40 Bore Link Clamp Link Clamp Force (kN)**	Link Clamp to Work Support Support Capacity Ratio
7.0	10.0	5.1	2.0	4.5	2.2
6.0	8.3	4.4	1.9	3.9	2.1
5.0	6.7	3.7	1.8	3.2	2.1
4.0	5.0	2.9	1.7	2.6	1.9

ILML10005-10 REV A *Using L9-1440-01 Arm **Using L9-1640-03 Lever

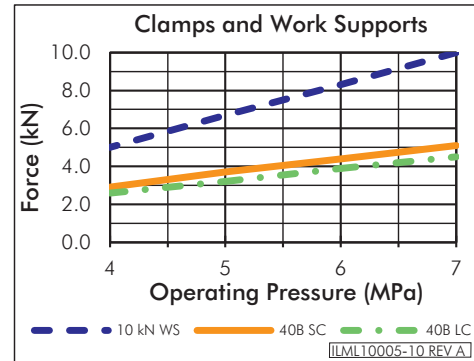

Operating Pressure (MPa)	16 kN Work Support Work Support Capacity (kN)	50 Bore Swing Clamp Swing Clamp Force (kN)*	Swing Clamp to Work Support Support Capacity Ratio	50 Bore Link Clamp Link Clamp Force (kN)**	Link Clamp to Work Support Support Capacity Ratio
7.0	16.0	7.6	2.1	7.6	2.1
6.0	13.3	6.5	2.0	6.5	2.0
5.0	10.7	5.4	2.0	5.4	2.0
4.0	8.0	4.3	1.9	4.4	1.8

ILML10005-16 REV A *Using L9-1450-01 Arm **Using L9-1650-03 Lever

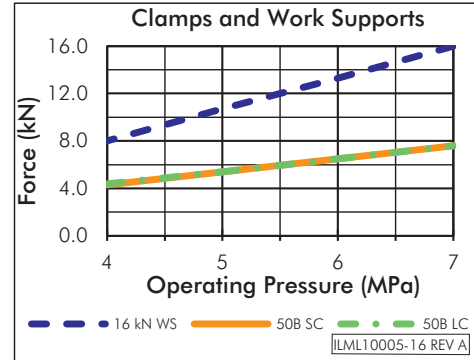

Operating Pressure (MPa)	26 kN Work Support Work Support Capacity (kN)	63 Bore Swing Clamp Swing Clamp Force (kN)*	Swing Clamp to Work Support Support Capacity Ratio	63 Bore Link Clamp Link Clamp Force (kN)**	Link Clamp to Work Support Support Capacity Ratio
7.0	26.0	12.0	2.2	12.6	2.1
6.0	21.7	10.3	2.1	10.8	2.0
5.0	17.3	8.6	2.0	9.0	1.9
4.0	13.0	6.9	1.9	7.2	1.8

ILML10005-26 REV A *Using L9-1463-01 Arm **Using L9-1663-03 Lever

