

# Accessory Valves

## Pilot Operated Check Valve

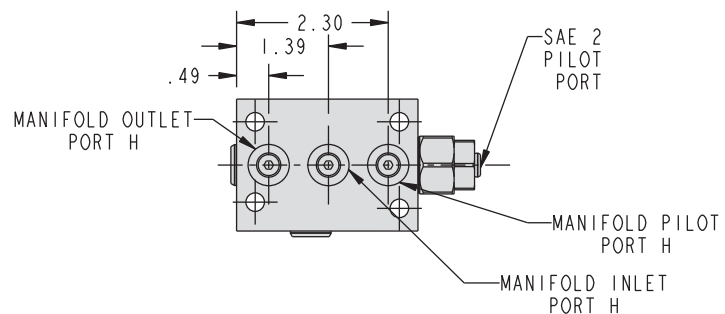
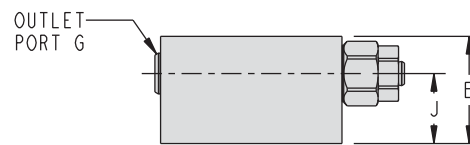
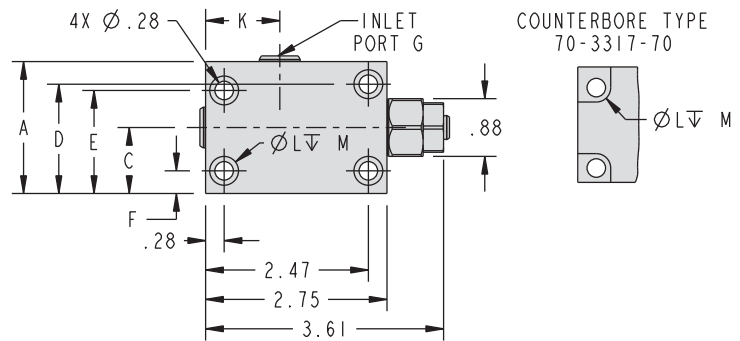

ILS703305 A

### Pilot Operated Check Valve

- Cartridge and Manifold Mount versions.
- Sealed pilot piston eliminates cross circuit leakage.
- 5:1 Ratio of Pilot to Check pressure for release.
- Unclamp device sequencer manages single circuit unclamp timing.
- Flows up to 1.5 gal/min at 5,000 psi maximum pressure.
- Stainless steel cartridge construction.

### Assembly Dimensions

Model No.	A	B	C	D	E	F	G	H	J	K	L	M
70-3311-13	2.00	1.63	1.00	1.66	1.56	0.34	SAE 6	SAE 2 Plug	1.06	1.13	0.28	0.44
70-3317-70	1.75	1.50	0.88	1.53	1.44	0.22	N/A	N/A	0.94	N/A	0.28	0.44

### Mounting Dimensions for Pilot Operated Check Valve Assemblies 70-3311-13 and 70-3317-70

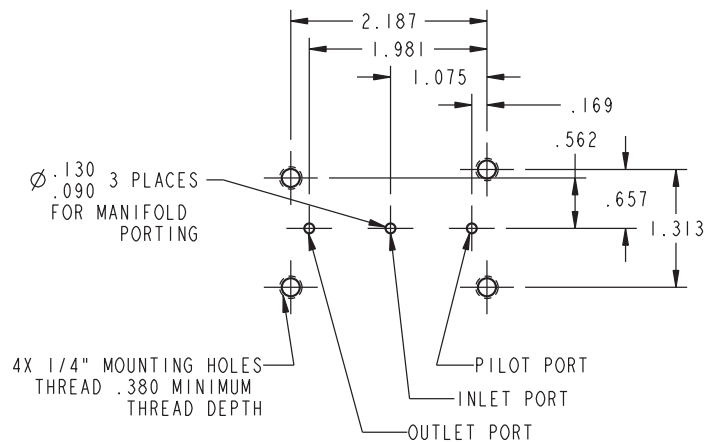

ILS703307 REV B

M-4

For proper sealing, mating surface must be flat to 0.003 in. with a maximum 63  $\mu$  in.  $R_a$  surface finish.



# Accessory Valves



## Pilot Operated Check Valve

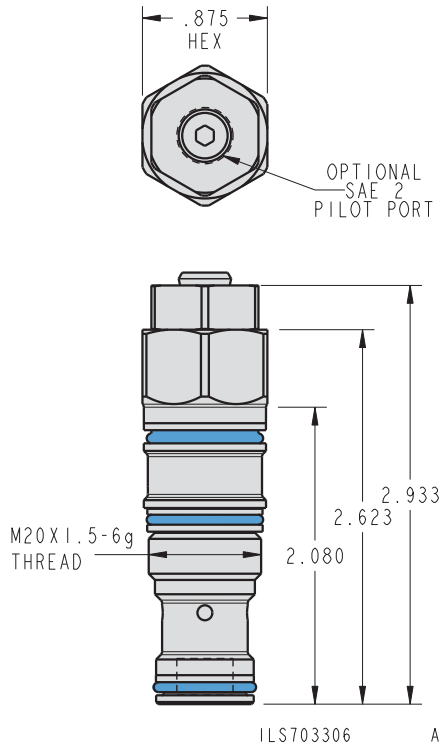

### PO Cartridge

Model No.  
70-3337-71



### Cartridge Mount Pilot Operated Check Valve Cavity Dimensions

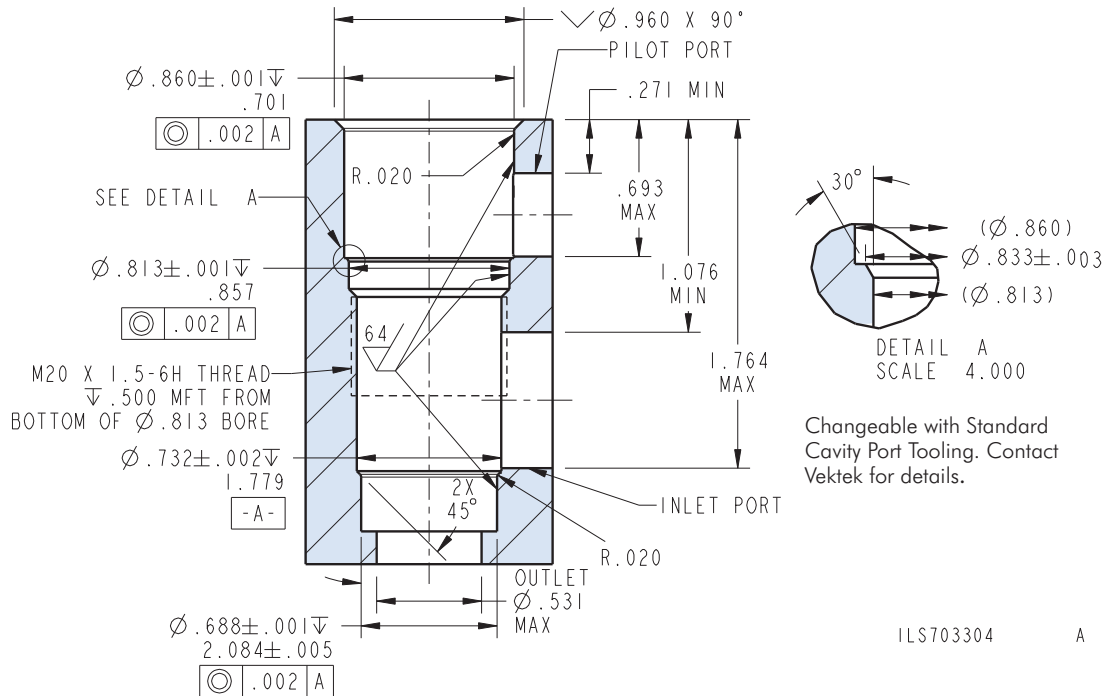

M-5

