



Palletized Fixture Accessories

Accumulators

Accumulators*

- Maintains circuit pressure while the pallet or tombstone is disconnected from the pump using a Decoupler or tombstone Top Plate.
- Piston-type, inert gas precharged accumulators compensate for pallet pressure changes during machining.
- Available in three operating ranges providing up to 62 cm³ of pressurized fluid reserve.
- G 1/4 Threads.

Hydraulic fluid compresses the precharged inert gas across the piston during circuit pressurization. The pressurized gas provides additional fluid to the circuit to reduce pressure changes in the event of small seeps, thermal expansion or contraction while the pallet or tombstone is in the machine.

- The 140 bar (14 MPa) to 350 bar (35 MPa) operating pressure model has gas precharged of 100 bar (10 MPa).
- The 70 bar (7 MPa) to 250 bar (25 MPa) operating pressure model has gas precharged of 50 bar (5 MPa).
- The 20 bar (2 MPa) to 100 bar (10 MPa) operating pressure model has gas precharged of 17 bar (1.7 MPa).

Perform annual maintenance in accordance with the instructions provided with each accumulator. Contact Vekttek for additional copies of the annual maintenance instructions or to arrange for factory performed annual maintenance.

* Strictly observe all safety precautions provided with each accumulator.



NEW
PRESSURE RANGE
20 Bar - 100 Bar

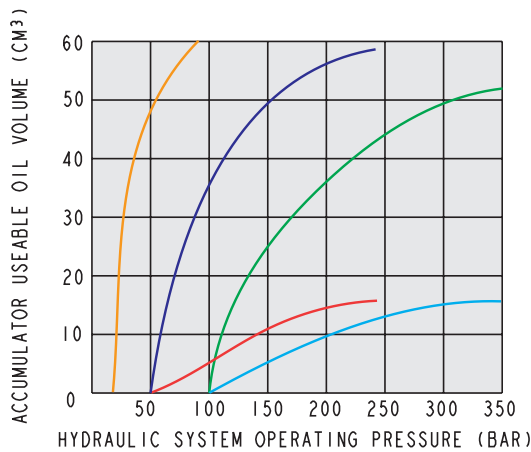

45-6001-02 PALLET DECOUPLER
or
49-0116-02 ACCUMULATOR

45-6001-01 PALLET DECOUPLER
or
49-0116-01 ACCUMULATOR

49-0116-05 ACCUMULATOR

49-0114-02 ACCUMULATOR

49-0114-01 ACCUMULATOR

ILMV101102 REV D

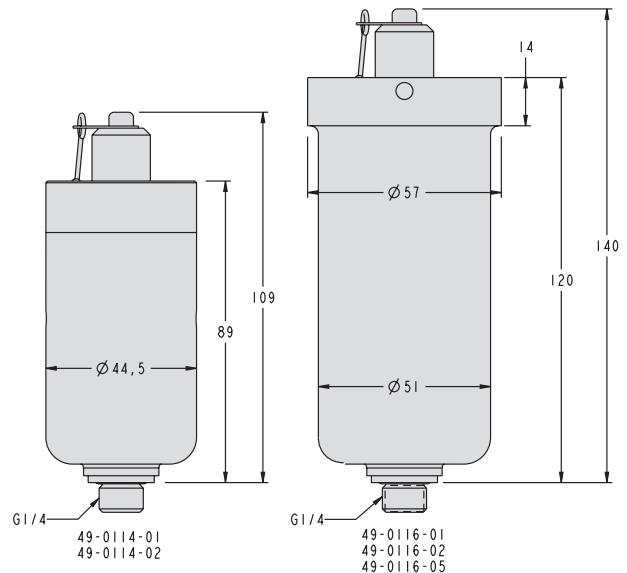

ILMV101000 REV F

Accumulator Model No.	System Operating Pressure	Approx. Usable Volume At Max. System Pressure
49-0114-01	140 bar-350 bar (14-35 MPa)	16 cm ³
49-0114-02	70 bar-250 bar (7-25 MPa)	16 cm ³
49-0116-01	140 bar-350 bar (14-35 MPa)	52 cm ³
49-0116-02	70 bar-250 bar (7-25 MPa)	59 cm ³
49-0116-05	20 bar-100 bar (2-10 MPa)	62 cm ³

NOTE: Please check accumulator's gas pre-charge during your annual maintenance check. Consult factory if you require assistance.

