

POWER PRESS

Made in the USA

Spring 2004

American Made, Makes Sense

American pride in craftsmanship produces some of the finest products in the world. Doggedly pursuing a better way of getting the job done is a hallmark of the American character. This spirit has given birth to everything from the light bulb to the space shuttle and creativity will push America forward in spite of global competitive pressure.

Ahaus Tool and Engineering, is one of the thousands of American businesses coping with global competition. Ahaus, a pioneer in new technologies and production processes for machine applications, is committed to building a quality product, in a timely manner, at a price that is competitive, to serve a global market. Ahaus Tool's reputation is marked by their client list of notable companies like Delphi, Visteon, Siemens-Westinghouse, HN Automotive and Caterpillar to name just a few.

Ahaus customers have little time to be waiting on component deliveries that delay fixture installation or extend machine downtime. Availability can mean the difference between a satisfied customer and opportunities lost. Rick Ahaus, *President, Ahaus Tool and Engineering* said, "Where possible, we steer customers to Vektek" workholding solutions. He cited the quality of the product, availability, timeliness of deliveries and the cost stability of products compared to other suppliers, as reasons to use Vektek workholding devices. "It's a lot easier to get product from Kansas than from offshore. When you're building the kind of fixtures we're building it makes a lot of sense to use **American Made Products.**"

Rick pointed out that there has been a time or two when there was a snag with a Vektek product. The Vektek Fluid Advance Work

Support was a specific instance of a product performing less than optimally in his specific application. These components were included in a fixture that was to be used in a harsh, contaminant laden, and coolant flooded environment.

The breathers on the work supports were pulling coolant into the device causing it to stick. The resolution to this specific instance was to modify the fluid advance work supports in such a way as to accommodate the customer's application. According to Mr. Ahaus, Vektek engineers

"work pretty closely with our project engineers ... to solve issues as quickly as possible."

Vektek customers, who will be using their fixtures in a similar environment and want a vent-less configuration for fluid advance work supports, have only to tell their Vektek representative when ordering. Customers who already have fluid advance work supports on their fixtures can order a shield to protect the breather. These shields, (found on page B-10 of the Vektek catalog) function similar to an umbrella, shielding the breather from direct high-pressure coolant, spray and other contaminants. The Technical Perspective article in this edition of **Power Press** is dedicated to Work Supports (pages 2 through 4) where you will find information on types, sizing and application recommendations to automate your machining processes.

"When companies like Vektek and Ahaus work together... it is an advantage to the customer, Ahaus and Vektek. It certainly is something I wish more companies would do."

Rick Ahaus, Ahaus Tool and Engineering



Features

American Made,
Makes Sense

New item: Pallet
Pressure Monitor

The Technical
Perspective:
Work Supports

VektorAir®



1334 East 6th Avenue
Emporia, KS 66801

800-992-0236

www.vektek.com

Good to Go!



“Hydraulic Pressure OK Signal” going straight to your machine controller.

The signal is coming to your machine controller from Vektek’s new wireless Pallet Pressure Monitor. The Pallet Pressure Monitor is a patent pending device designed to confirm the presence of a preset minimum hydraulic pressure on your system. This allows you to hold a part on a fixture hydraulically and have pressure confirmed as the pallet passes into, out of, or during the machining cycle. Both the transmitter and receiver are sealed units and are designed to run in your machining environment allowing the machine controller to keep in touch at all times. The monitor eliminates the need for your operator to confirm pressure before machining.

This monitoring system gives you a signal transmission range up to 8 inches, wireless communication between the transmitter and receiver and no electrical power requirement on the pallet, ever. You will sleep better when you turn the “Lights Out” whether your machines run manned or unmanned, one shift or three shifts per day. Each and every pallet can have pressure confirmed by the controller prior to machining, no operator confirmation required - EVER.

Learn more about this fantastic new product and the many fine VektorFlo® and VektorAir® products available through Vektek by calling

800-992-0236

The Pallet Pressure Monitor will verify system pressure is at or above user defined minimum acceptable pressure prior to or during machine cycle. Patent pending.

- Wireless communication between transmitter and receiver
- No electrical power required on pallet
- Up to 8” Range
- Pallets may be loaded days or hours prior to machine entry and confirmed before machining
- Use with Pressure Switch model 70-7500-75, ordered separately
- Receiver may be used with multiple transmitters set at various pressure levels
- No more than one transmitter may be within the receiver range at any time
- Capable of continuous or sample monitoring
- Receiver may be mounted inside machine enclosure for continuous monitoring during machining

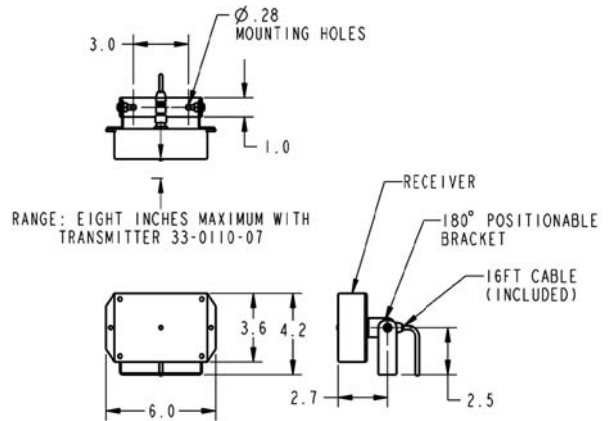

Specifications

- Nominal Regulated Supply- Voltage 24 Volts DC
- Supply Voltage Range - 14 to 28 Volts DC
- Supply Current with Relay OFF 43 ma
- Supply Current with Relay ON 58 ma
- Input Power Polarity Reversal Protection - Yes
- Input Transient Protection Up to 35 Volts DC
- Output Relay Current Rating - 3 amps
- Led Indicator - Green
- Protection - IEC IP 67
- Weight of Receiver Unit 33-0110-00 - 1.2 pounds
- Weight of Transmitter Unit 33-0110-07 - 0.9 pounds
- Weight of Cable 27-6222-02 - 0.4 pounds

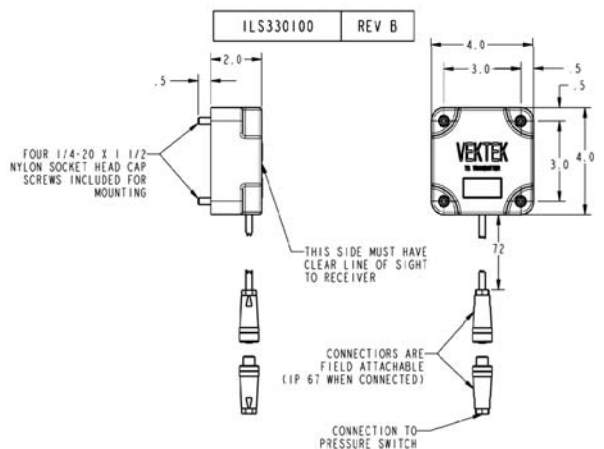

PALLET PRESSURE MONITOR TRANSMITTER MODEL NUMBER 33-0110-07
NO POWER SOURCE REQUIRED - UNIT IS SELF POWERED FOR THE LIFE OF THE PRODUCT
USE WITH PRESSURE SWITCH MODEL NUMBER 70-7500-75
SIMPLE WIRING: CONNECT THE TRANSMITTER TO THE PRESSURE SWITCH WITH THE PROVIDED CONNECTORS

ILS330102 REV C



800-992-0236

The Technical Perspective: WORK SUPPORTS

Work supports are supplementary devices to be used along with rigid support and /or locating points on a fixture. They help to compensate for minor part variation during loading and imposed deflections during clamping and machining operations. The effects of vibration and deflection are minimized by the use of work supports, resulting in consistent finished work-piece accuracy.

Work supports use a hydraulically compressed sleeve to lock the plunger in place once it has engaged the work-piece. On Fluid Advance and Spring Advance models, the spring force on the plunger determines the contact force on the work-piece. In the case the Air Advanced work support, the air inlet pressure on the plunger determines the contact force.

Air Advance Work Support

Available in four capacities (1,000 to 12,500 lb.), this type of work support uses air pressure to advance the plunger and contact the work-piece. The contact force of the plunger can be adjusted by means of an air regulator. By leaving the air pressure applied at all times, the plunger will function as an air spring.

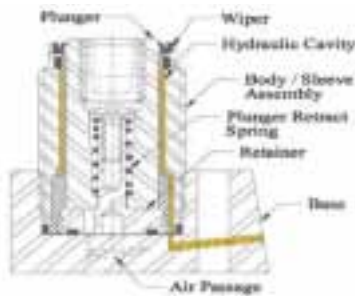

Air Advance work supports are well suited for use in environments that contain contaminants such as cast iron grit or aluminum fines. The absence of internal air seals allows air to escape around the plunger. This escaping air, when left on, continuously purges the sleeve/plunger contact area preventing contamination in the device. This design element results in operational efficiency and longer support life.

When the plunger is extended and used as an air spring, work-piece movement may occur when the hydraulic pressure is removed. Once the plunger is advanced to the workpiece, it is locked in place by applying hydraulic pressure to the internal compression sleeve through a separate hydraulic port. An internal return spring will retract the plunger for clearance to load and unload work-pieces after both the hydraulic and the extend air pressure have been removed.

Spring Advance Work Support

Available in four capacities (1,000 to 12,500 lb.), this type of work support uses an internal spring to maintain an extended plunger when the work support is not loaded. It is typically used when a part is heavy enough to depress the plunger and when the plunger will not interfere with



work-piece positioning during loading and unloading. Spring extended plungers maintain contact with the part as it is loaded, exerting only spring force against the part. Once parts are loaded and the spring loaded plunger partially depressed, it is locked in place by applying hydraulic pressure to the internal compression. As spring force is always present on the plunger, the work piece could move when the hydraulic pressure is removed.

If Spring Advance work supports must be used in flood coolant environments (we recommend air advance), attach tubing to the vent port and route it to a clean, dry air source. This will minimize coolant being drawn in and becoming sticky on internal surfaces.

Fluid Advance Work Support

Available in three capacities (1,000 to 4,000 lb.), this type of work support uses hydraulic pressure to advance an internal piston. The piston pushes against a spring, advances the spring to lift the plunger. The piston and spring always travel full stroke regardless of

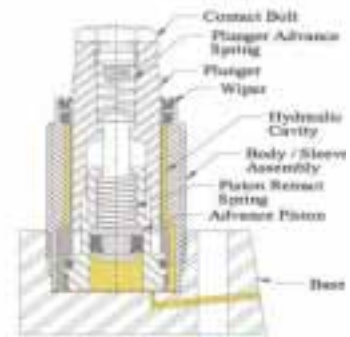

the hydraulic pressure. The plunger stops when it encounters a workpiece. An internal restriction sequences the compression sleeve locking the mechanism after the spring extends the plunger. These units use a separate spring to return both the piston, and plunger after the hydraulic pressure is removed.

Fluid Advance work supports work well when sequencing is required for the clamping operations or when the plunger must be retracted to clear for work-piece loading and unloading. These work supports are especially useful when avoiding the introduction of a secondary power supply.

Fluid Advance work supports have a breather port plug option available. This **NEW** vent-less configuration eliminates fluid entrance into the internal areas of the of the work support through the breather port. Specify your preference for vent-less when ordering.

Fluid Advance work supports should not be used if advance force control is required (varying the hydraulic pressure in the system does not have any effect on the spring contact force). The use of a power supply with a flow rate above 130 cu. in./minute may cause the compression sleeve to prematurely engage the plunger before it can be lifted into position by the spring. Excessive flow rates may also accelerate the plunger so that it bounces off the work-piece and becomes engaged by the compression sleeve before it can re-contact the workpiece.



800-992-0236

Sizing the Work Support

The total load will determine the size work support needed. This load is based on the following factors:

- The anticipated force being exerted on the work support due to the operation being performed against it (part weight is typically supported by fixed stops and therefore would not be a contributing factor).
- Clamping force over a work support (plan no less than a 2:1 ratio of support to clamp force)
- If the work support is subjected to severe vibrations or “hammering” such as those generated from an interrupted cut, a minimum safety factor of 5:1 of the anticipated load should be considered.

Using the work support selection Chart 1 below, find the anticipated capacity requirement for your application, including clamp and work loads, in the left hand column. Follow across the chart to the right until your application load intersects the anticipated hydraulic operating pressure of the system. Choose the size of work support needed from the curve that intersects this point or from the nearest curve **above** the required point.

WORK SUPPORT SELECTION CHART

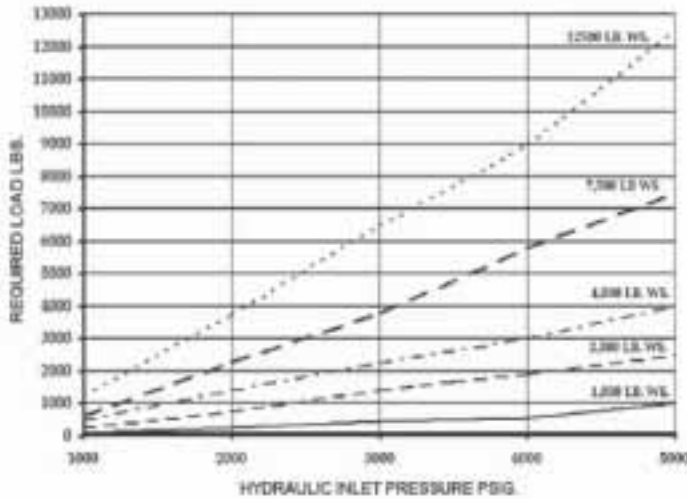

Chart 1

Referring to Chart 2, if the system pressure is intended to operate at 2500 psi, the work support will resist roughly 1050 lbs. of force. The clamp shown in the chart will produce approximately 550 lbs. of clamp force at the same hydraulic pressure. This results in approximately 500 lbs. of support force to resist the operation being performed on the work-piece. If more support resistance is required, the system pressure must be increased, the size of the work support must be increased, or the size of the clamp must be decreased. If a larger capacity clamp must be used for any reason, the hydraulic pressure supplied to the clamp must be reduced to limit the clamp force accordingly.

Caution: If the hydraulic system pressure is inadequate for

anticipated load, the work support will not provide the desired support capacity.

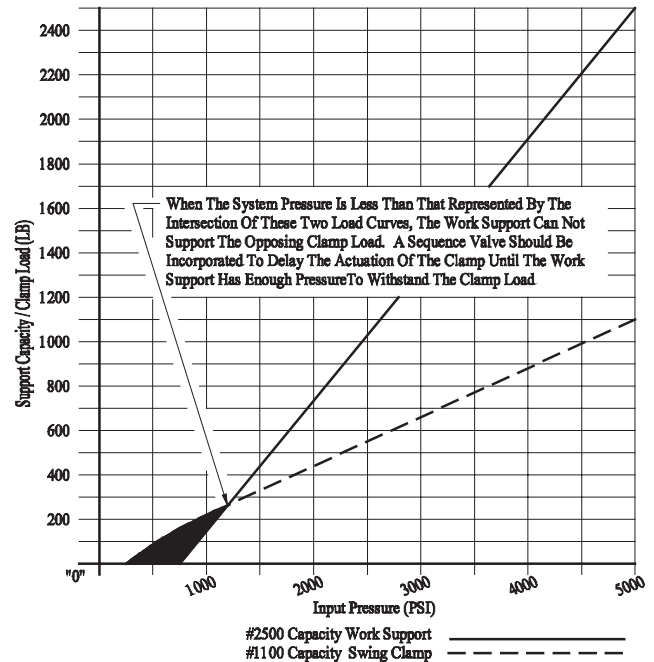

Chart 2

General Information

- Never use a work support to move a load. A work support is not a cylinder and will not perform the same function as a cylinder.
- Never “strike” or “rap” the end of the plunger to see if it is locked in place. A 16-penny nail protruding from a board will support many times the weight of a hammer and all of the force you can push with the hammer. However, the shock load generated by striking the nail with the hammer will drive the nail into the board. The work support will move in similar fashion when struck.
- Typically, the work support should be installed so that the plunger engages a work-piece at one half of the total stroke. This positioning will allow the stroke of the work support to compensate for reasonable variations from one work-piece to the next.
- The metal components on the work support are corrosion resistant.
- The maximum system backpressure a fluid advanced work support can readily overcome is 10 psi. Backpressures greater than 10 psi during the return or unclamp cycle result in work support slow retraction or failure to retract. The use of spool valves to control work supports is discouraged. Please use Vektex “zero leak” valves.

Fluid / Coolant Compatibility

Work supports are furnished with polyurethane seals as standard. This compound provides excellent service in a wide variety of coolant applications. However, before using work supports in synthetic or water-based coolants contact your coolant manufacturer or supplier for seal compatibility recommendations.

Fluorocarbon seals are available as an option, but have a significantly shorter life than standard seals.

When the fixture is taken out of service, it is important that the work supports be cleaned of coolant residue before storage. Failure to clean this residue may result in the work supports sticking when returned to service.

The work supports are designed to function with an ISO 32 grade hydraulic fluid. Contact your fluid manufacturer for seal compatibility recommendations if use of a synthetic or water based hydraulic fluid is intended.

Application Information

- Maximum Hydraulic Operating Pressure - 5,000 psi
- Minimum Hydraulic Operating Pressure - 750 psi
- Maximum Operating Temperature for standard seals is - 160° F
- Minimum Operating Temperature to maintain viscosity is - 40° F
- Maximum Flow Rate - 350 cu. in./min. for Spring Advance and Air Advance Work Supports. Maximum Flow Rate for Fluid Advance Work Supports is 130 cu. in./min.
- Hydraulic Fluid Filtration - 25-micron

Application Recommendations

Work supports can be mounted in any position relative to the work-piece, however for optimal life and performance, the loading should be axial to the work support. When ever possible, avoid severe angular or offset loading applications.

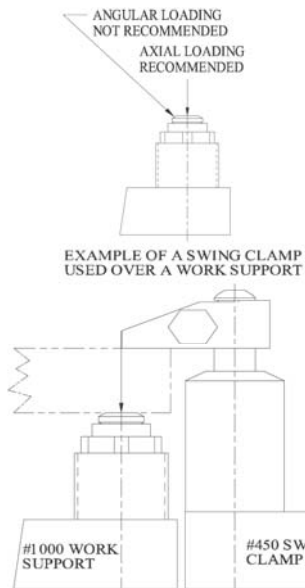

Hydraulic Circuits

For best performance, hydraulic circuits should be designed so that the work supports are not “daisy chained” together (or at least to a bare minimum) and have adequate hydraulic fluid passage size to prevent excessive backpressure.

When used in conjunction with other devices the hydrau-

lic fluid passages for work supports should either be isolated from other devices or sized so that return flow from these devices do not prevent work supports from returning due to induced backpressure.

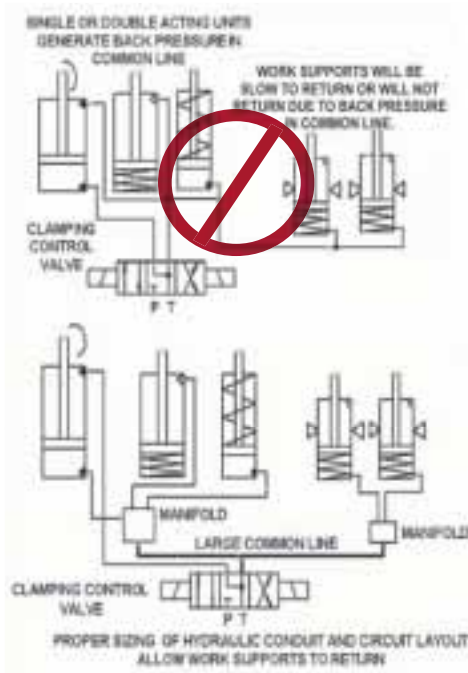

Always provide enough timing or provide proper sequencing to insure complete lock up of work support before loading. As an alternate to this be sure the part is fully and properly located before activating work support.

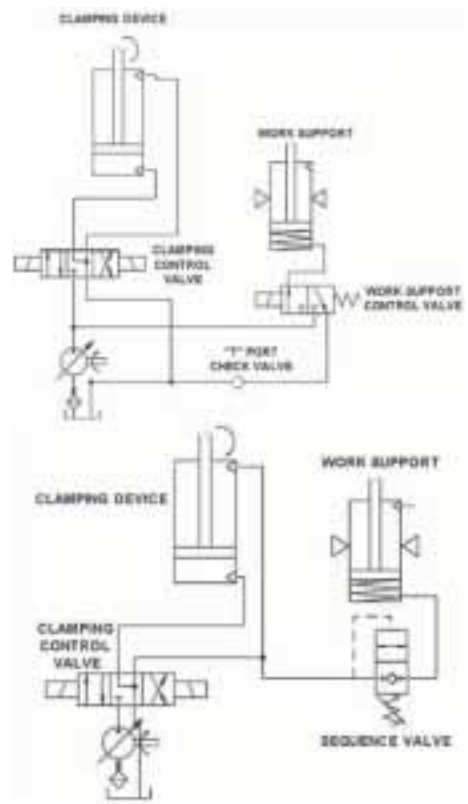

These Illustrations show two proper ways to control work support sequencing, either before or after other clamping actu-ates.



800-992-0236



1334 East 6th Avenue
Emporia, KS 66801

**SEE OUR
NEW ITEMS**
at



Tooling & Workholding
Pavilion
Vektek-Booth E-2223

PRECISION PNEUMATIC CLAMPING

AIR POWER

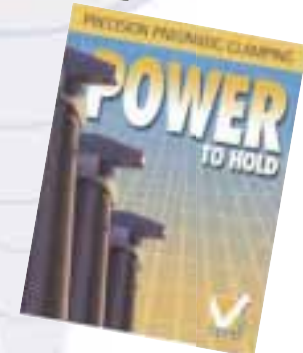

Need to Automate?

Capture the power of air!

If you thought the processes that use manual clamping in your operation couldn't be made more efficient, it's time you took a look at VektorAir™ Precision Pneumatic Clamping. Durable enough for use in machining and welding operations, VektorAir™ workholding products are also a good fit for woodworking, assembly and automation.

Years of trouble-free operations are yours because Vektek workholding products are built to last. Designed to run on standard shop air of 80 psig, these clamps offer you consistent and reliable clamping force, easy connection with push-to-connect tubing, dynamic seals of compounded elastomer and hardened internal and external components to extend clamp life.

MAKE YOUR SHOP AIR WORK HARDER.

Call 800-992-0236

for a

FREE CATALOG

